

## Instructions for use



  
**PATTERSON**<sup>®</sup>  
DENTAL

**PD-96 LM, PD-96 RM**

# Contents

---

<b>Symbols</b> .....	4
<b>1. Introduction</b> .....	6
<b>2. Safety notes</b> .....	9
<b>3. Product description</b> .....	12
PD-96 LM .....	12
PD-96 RM .....	13
<b>4. Operation</b> .....	14
Assembly/Removal PD-96 LM .....	14
Assembly/Removal PD-96 RM.....	15
<b>5. Hygiene and maintenance</b> .....	19
General notes .....	19
Limitations on processing.....	21
Initial treatment at the point of use.....	22
Manual cleaning.....	23
Manual disinfection .....	26

Automated cleaning and disinfection .....	27
Drying .....	28
Inspection, Maintenance and Testing .....	29
Packaging .....	33
Sterilization .....	34
Storage.....	36
<b>6. Maintenance .....</b>	<b>37</b>
Changing the water filter .....	37
Cleaning the water filter .....	38
Changing the turbine PD-96 RM .....	39
<b>7. Troubleshooting .....</b>	<b>41</b>
<b>8. Servicing .....</b>	<b>42</b>
<b>9. Accessories and spare parts.....</b>	<b>43</b>
<b>10. Technical data .....</b>	<b>44</b>
<b>11. Disposal.....</b>	<b>47</b>
<b>Warranty.....</b>	<b>48</b>



**WARNING!**  
(risk of injury)



**CAUTION!**  
(to prevent damage  
occurring)



General explanations,  
without risk to  
persons or objects



Do not dispose of with  
domestic waste

## Symbols

on the medical device / packaging



Sterilizable up to the stated temperature



Catalog number



Serial number



Date of manufacture



Thermo washer disinfectable



DataMatrix Code for product information including UDI (Unique Device Identification)



Data structure in accordance with Health Industry Bar Code



UL Component Recognition Mark indicates compliance with Canadian and U.S. requirements



Caution! According to Federal law, this medical device may only be sold by or on the order of a dentist, physician or any other medical practitioner licensed by the law of the State in which he or she practices and who intends to use or order the use of this medical device.

## 1. Introduction

---

This medical device has been developed, manufactured and subjected to final inspection according to legal regulations, quality and industry standards.

### **For your safety and the safety of your patients**

Prior to initial use please read the instructions for use completely; they explain how to use your medical device and ensure proper, efficient and safe operation.



Observe the safety notes.

### **Intended use**

The dental turbine handpiece is intended for the following applications: Removal of decayed materials, cavities and crown preparation, removal of fillings, finishing of tooth and restoration surfaces.



Misuse may damage the medical device, and hence cause risks and hazards for patient, user and third parties.

### **Qualifications of the user**

We have based our development and design of the medical device on the dentists, dental hygienists, dental employees (prophylaxis) and dental assistants target group.

### **Device labeling statement**

U.S. Federal law restricts this device to sale by or on the order of a dentist, physician, or any other practitioner licensed by the law of the state in which he or she practices to use or order the use of this device.

### **Responsibility of the manufacturer**

The manufacturer can only accept responsibility for the safety, reliability and performance of the medical device when it is used in compliance with the following directions:

- > The medical device must be used in accordance with these Instructions for use.
- > Only the components approved by the manufacturer may be replaced (turbine, O-rings and water filter).
- > Repairs must only be undertaken by an authorized Patterson repair location.

**Skilled application**

The medical device is intended for use only by trained dental or medical practitioners for the purposes listed under the Indications for Use, in accordance with this document, the applicable health and safety regulations, and the valid accident prevention regulations.

The medical device should be prepared for use and maintained by staff who are trained in procedures for infection control, personal safety, and patient safety.

Improper use, (e.g., through poor hygiene and maintenance), noncompliance with our instructions, or the use of accessories, and spare parts that are not approved invalidates all claims under warranty and any other claims.

**Service**

In the event of operating malfunctions immediately contact your local Patterson Representative or call your local Patterson Branch at 800-873-7683.

Repairs and maintenance work must only be undertaken by authorized Patterson repair locations.



## 2. Safety notes



- > The operation of the medical device is permitted only on supply units which correspond to the standards IEC 60601-1 (EN 60601-1) and IEC 60601-1-2 (EN 60601-1-2).
- > Before using the medical device for the first time, store it at room temperature for 24 hours.
- > Use only the supply hoses as specified by EN ISO 9168.
- > Always ensure the correct operating conditions and cooling function.
- > Always ensure that sufficient and adequate cooling is delivered and ensure adequate suction.
- > In case of coolant supply failure, the medical device must be stopped immediately.
- > Use only the filtered, oil-free and cooled air supplied by dental compressors for drive air.
- > Check the medical device for damage and loose parts before each use (e.g. push-button).
- > Do not operate the medical device if it is damaged.
- > Perform a test run before each use.



- > Avoid overheating at the treatment site.
- > Do not use the medical device if there are soft tissue wounds in the mouth. The air pressure can cause septic substances to enter the tissue or trigger embolisms.
- > Do not lift the cheek or tongue with the medical device. Risk of burning due to the push-button heating up!
- > Run the rinse function for the dental unit once per day.
- > Do not use the medical device as a light probe.
- > Do not look directly into the LED.

## Hygiene and maintenance prior to initial use



- > The medical device is sealed in PE film and not sterilized when delivered.
- > The PE film and the packaging are non-sterilizable.



- > Clean, disinfect and lubricate the medical device.
- > Sterilize the medical device and the nozzle cleaner.

### 3. Product description

PD-96 LM

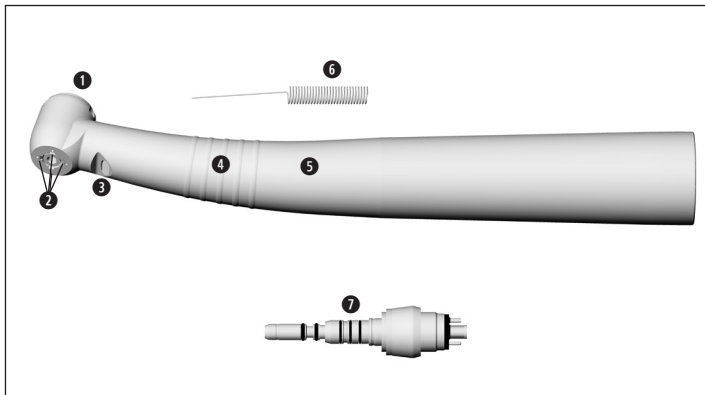

- ① Push-button chuck
- ② Spray ports
- ③ Optic outlet (glass rod)
- ④ Grip
- ⑤ Sheath
- ⑥ Cleaning wire
- ⑦ Connection

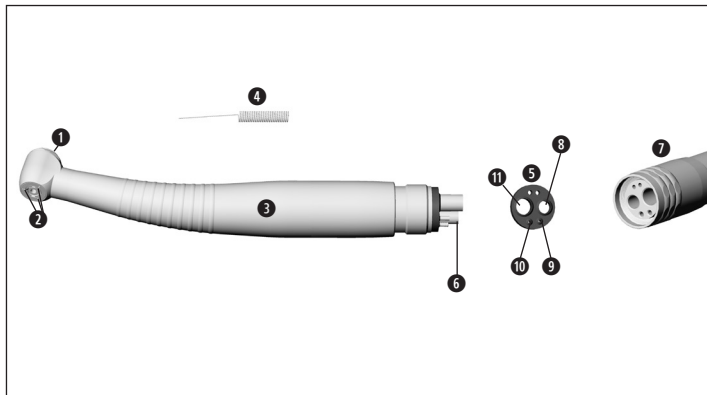

- ① Push-button chuck
- ② Spray ports
- ③ Sheath
- ④ Cleaning wire
- ⑤ Gasket
- ⑥ Water filter with resuction stop
- ⑦ Supply hose

### Connections

- ⑧ Drive air
- ⑨ Coolant
- ⑩ Spray air
- ⑪ Exhaust air



**Do not assemble / remove during operation!**

**1** Attach the medical device to the Multiflex<sup>®</sup> coupling as described by the coupling manufacturer.



**2** Check that the connection to the coupling is secure.

**3** Remove the Multiflex<sup>®</sup> coupling as described by the coupling manufacturer.

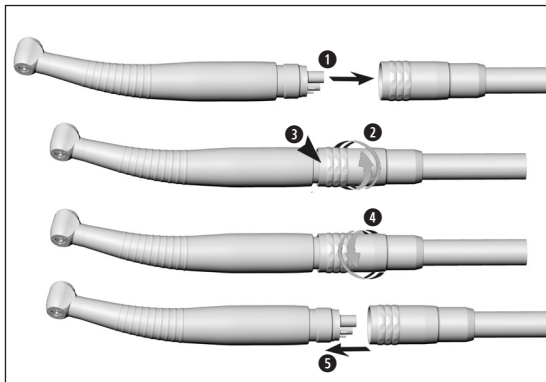

**Do not assemble / remove during operation!**

- 1 Insert the medical device into the apertures of the tubing.
- 2 Firmly screw the medical device and the coupling nut together.
- 3 Check for leaks at the connection.



- 4 Check that the connection to the coupling is secure.

or

- 5 Unscrew the coupling nut.
- 6 Pull the medical device from the from the tubing.

## Dental burs



- > Use only dental burs which are in perfect condition. Follow the operating instructions of the manufacturer.
- > Insert the dental bur only when medical device is stationary.
- > Do not interfere with the running or slowing down dental bur.
- > Do not activate the push-button of the medical device during operation or slowing down. This leads to detachment of the dental bur resp. heating of the push-button (risk of injury).
- > Only use dental burs up to the maximum operating speed stipulated by the manufacturer.



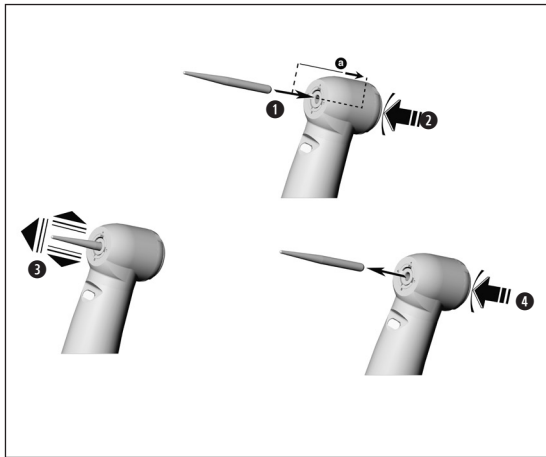

## To change dental bur

- 1 Insert the dental bur.
- 2 Activate push-button chuck, at the same time insert the dental bur until back stop [a].



- 3 Verify full engagement.

- 4 Remove the dental bur by pushing the push-button.

## Test run



**Do not hold the medical device at eye level!**

- > Insert the dental bur.
- > Start the medical device.



In the event of operating malfunctions, such as vibrations, unusual noise, overheating, smell, coolant supply failure or leakage, **stop the medical device immediately** and contact an authorized Patterson repair location.



Follow your local and national laws, directives, standards and guidelines for cleaning, disinfection and sterilization.



> Wear protective clothing, safety glasses, face mask and gloves.



> Use only oil-free, filtered compressed air with a maximum operating pressure of 3 bar for manual drying.

## Cleaning agents and disinfectants



- > Read the notes, follow the instructions and heed the warnings provided by the manufacturers of cleaning agents and/or disinfectants.
- > Use only detergents which are intended for cleaning and/or disinfecting medical devices made of metal and plastic.
- > It is imperative to comply with the concentrations and exposure times specified by the manufacturer of the disinfectant.
- > Use disinfectants which have been tested and found effective by, for example: the Food and Drug Administration (FDA) or the U.S. Environmental Protection Agency (EPA).



The user is responsible for validating its process if the specified cleaning agents and disinfectants are not available.

 The product lifetime and the medical device's ability to operate correctly are mainly determined by mechanical stress during use and chemical influences due to processing.

- > Send worn or damaged medical devices and/or medical devices with material changes to an authorized service partner.

 **Processing cycles**

- > We recommend a regular service for the Patterson medical device after 1,000 processing cycles or one year.



Clean and disinfect the medical device immediately after every treatment, to flush out liquid (e.g., blood, saliva etc.) and to prevent settling on the internal parts.

- > Operate the medical device for at least 10 seconds at idle speed.
- > Ensure that all outlets are rinsed out.



- > Wipe the entire surface of the instrument with disinfectant.
- > Remove the dental bur.
- > Remove the medical device.



Note that the disinfectant used during pre-treatment is only for personal protection and cannot replace the disinfectant step after cleaning.



Do not place the medical device in liquid disinfectant or in an ultrasonic bath!

- > Clean the medical device under running tap water (<35°C / 95°F).
- > Rinse and brush off all internal and external surfaces.
- > Move moving parts back and forth several times.
- > Remove any liquid residues using compressed air.



### **Cleaning of the spray ports**

- > Clean coolant outlets carefully with the cleaning wire to remove dirt and deposits.



The cleaning wire can be cleaned in an ultrasonic bath and/or in the washer-disinfector.

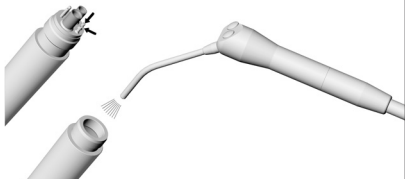

### **Cleaning of the coolant tubes**

- > Blow through the coolant tube using compressed air.



In case of blocked coolant outlets or coolant tubes contact an authorized Patterson repair location.



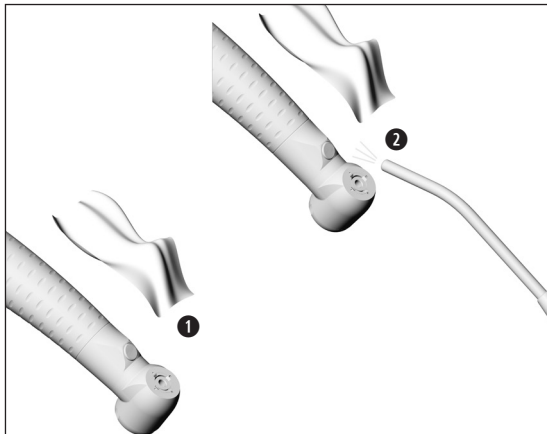

## Cleaning of the optic outlet



**Avoid scratching of the optic outlet!**

- ➊ Wash the optic outlet with cleaning fluid and a soft cloth.
- ➋ Blow the optic outlet dry using compressed air or dry it with a soft cloth.



- > Carry out a visual inspection after each cleaning process.
- > Do not use the medical device if the optic outlet is damaged and contact an authorized Patterson repair location.



> Patterson recommends wiping down with disinfectant.



Evidence of the medical device's basic suitability for effective manual disinfection was provided by an independent test laboratory using the »mikrozid<sup>®</sup> AF wipes« disinfectant (Schülke & Mayr GmbH, Norderstedt).



Patterson recommends automated cleaning and disinfection using a washer-disinfector (WD).

- > Read the notes, follow the instructions and heed the warnings provided by the manufacturers of washer-disinfectors, cleaning agents and/or disinfectants.



Evidence of the medical device's basic suitability for effective automated disinfection was provided by an independent test laboratory using the »Belimed WD 100« (Belimed AG) washer disinfector, the »deconex 24 LIQ« cleaning agent (Borer Chemie) and the neutralizer »deconex 26 plus« (Borer Chemie) according to ISO 15883.

- > Cleaning at 65°C (149°F) – 5 minutes
- > Disinfection at 90°C (194°F) – 5 minutes



- > Ensure that the medical device is completely dry internally and externally after cleaning and disinfection.
- > Remove any liquid residues using compressed air.

### Inspection



- > Check the medical device after cleaning and disinfection for damage, visible residual soiling and surface changes.
- > Reprocess any medical devices that are still soiled.
- > Sterilize the medical device following cleaning, disinfection and lubrication.

## Lubrication



- > Lubricate the dry medical device immediately after cleaning and/or disinfection.
- > Direct the medical device downwards.

### **Recommended lubrication cycles**

- > Essential after every internal cleaning.
  - > Before each sterilization.
- or
- > After 30 minutes of use or at least twice daily.
  - > Chucking system once a week.

### **With a high quality handpiece lubricant 085-2715**

- > Follow the instructions on the oil spray can and on the packaging.

or

### **With a general handpiece maintenance unit 035-4035**

- > Follow the instructions in the Instructions for use of the maintenance unit.

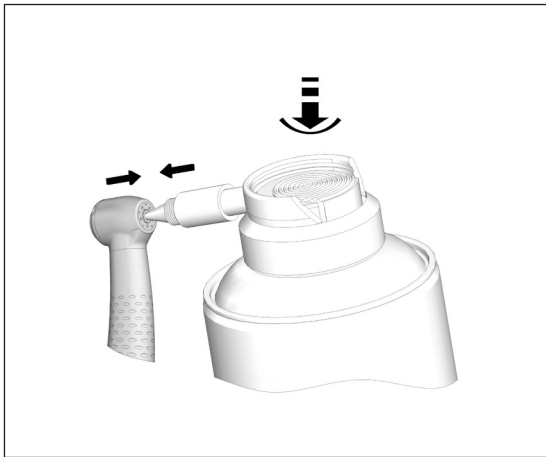

## Lubrication of the chucking system

### With a high quality handpiece lubricant

- > Fit the spray adaptor onto the spray can.
- > Hold the medical device firmly.
- > Press the tip of the spray adaptor firmly into the chucking system.
- > Spray for approx. 1 second.

## Testing after lubrication



- > Direct the medical device downwards.
- > Operate the medical device so that excess oil can escape.
- > Remove excess oil.





Pack the medical device and the accessories in sterilization packages that meet the following requirements:

- > The sterilization package must meet the applicable standards in respect of quality and use and must be suitable for the sterilization method.
- > The sterilization package must be large enough for the sterilization goods.
- > The filled sterilization package must not be under tension.



Patterson recommends sterilization according to EN 13060, EN 285 or ANSI/AAMI ST79.



- > Read the notes, follow the instructions and heed the warnings provided by the manufacturers of steam sterilizers.
- > The program selected must be suitable for the medical device.

### **Recommended sterilization procedures**

- > Fractionated pre-vacuum process (type B)
- > Gravity displacement process (type N)
- > Sterilization time at least 3 minutes at 134 °C (273 °F), 4 minutes at 132°C (270°F), 30 minutes at 121 °C (250 °F)
- > Maximum sterilization temperature 135 °C (275 °F)



**Evidence** of the medical device's basic suitability for effective sterilization was provided by an independent test laboratory using the LISA 522\* steam sterilizer (W&H Sterilization S.r.l., Brusaporto (BG)) and the Siroclav S3\*\* gravitation sterilizer (Sirona).

- > Fractionated pre-vacuum process (type B): temperature 134°C (273 °F) – 3 minutes\*
- > Gravity displacement process (type N): temperature 121 °C (250 °F) – 30 minutes\*\*

\* EN 13060, EN 285, ISO 17665

\*\* ANSI/AAMI ST55 , ANSI/AAMI ST79

- 
- > Store sterile goods dust-free and dry.
  - > The shelf life of the sterile goods depends on the storage conditions and type of packaging.

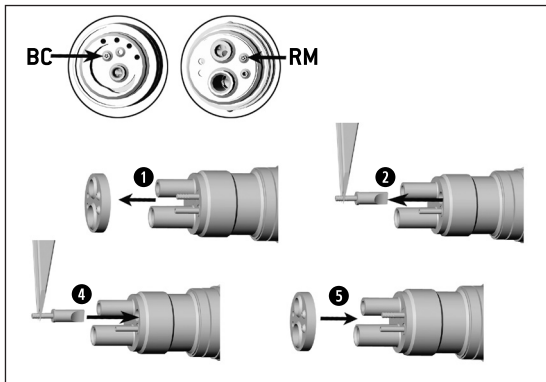

- 1** Remove the gasket.
- 2** Pull the water filter out using a pair of tweezers.
- 3** Clean the water filter (see page 39).  
or
- 4** Insert the new water filter.
- 5** Slide on the gasket.

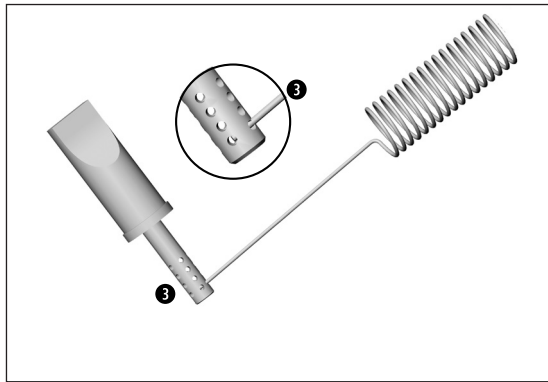

- 3** Clean outlets carefully with the cleaning wire to remove dirt and deposits.



The water filter may be cleaned in an ultrasonic bath.



> Repeat the complete cleaning and maintenance process.

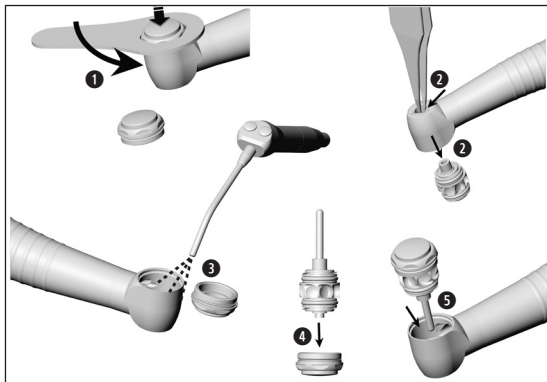

- 1 Unscrew the push-button using the hexagon wrench.
- 2 Push the turbine out of the turbine head using the tip of a pair of tweezers.



Clean the inside of the turbine head and the push-button with a cloth soaked in isopropyl alcohol.

- 3 Blow dry the push-button and the turbine head with compressed air.
- 4 Place the new turbine into the push-button.
- 5 Place the turbine with the push-button into the turbine head.

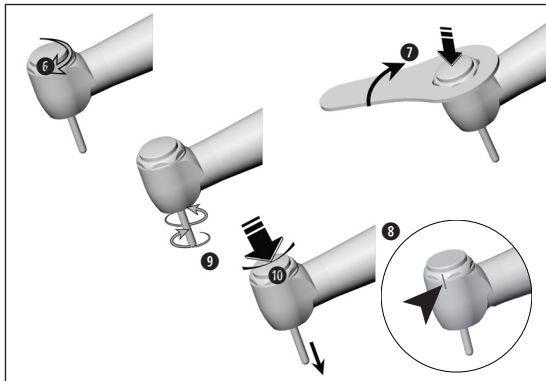

- 6 Screw the push-button onto the turbine head.
- 7 Tighten the push-button using the hexagon wrench, turning it clockwise up to the mark. 8
- 9 Check free running of the chucking system.
- 10 Activate the push-button chuck and remove the mandrel.



- > Perform a test run.
- > Repeat the complete cleaning and maintenance process.



## 7. Troubleshooting

Malfunction	Correction of malfunctions
Insufficient power	<ul style="list-style-type: none"><li>&gt; Check the connection between the medical device / coupling and supply hose</li><li>&gt; Check the operating pressure</li><li>&gt; Perform a lubrication</li><li>&gt; Change the turbine</li></ul>
Insufficient/no cooling	<ul style="list-style-type: none"><li>&gt; Check the operating pressure</li><li>&gt; Clean the spray ports</li><li>&gt; Clean/change the water filter</li></ul>
Inadequate hold of rotating instrument	<ul style="list-style-type: none"><li>&gt; Perform a lubrication</li><li>&gt; Change the push-button</li><li>&gt; Change the turbine</li></ul>

## 8. Servicing

---

### Repairs and returns

In the event of operating malfunctions immediately contact your local Patterson representative or call your local Patterson branch at 800-873-7683.

Repairs must only be undertaken by an authorized Patterson service partner.



> Ensure that the medical device has been completely processed before returning it.

## 9. Accessories and spare parts

---

 Use only original Patterson accessories and spare parts or accessories approved by Patterson.

083-6254 PD-96 RM spare high-speed handpiece

112-7331 PD-96 RM spare turbine kit

083-6346 PD-96 LM spare high-speed handpiece

089-3149 Seal RM

085-2715 Handpiece lubricant

## 10. Technical data

Turbine handpiece		PD-96 LM	PD-96 RM
Connection according to standard	EN ISO 9168:2009 hose-side	Multiflex®*	Standard 6-hole
Dental burs	ISO 1797 (Ø mm)	1.6 – 0.01	
Maximum length approved	(mm)	21**	
Minimum chuck length		until back stop	
Maximum operating part diameter	(mm)	2	
Idle mode speed (± 30,000)	(rpm)	390,000	
Coolant supply volume	ISO 14457 (gal/min)	> 0.013	
Water setting range (recommended water pressure)	(psi)	10 – 29 (22)***	
Chip air setting range (must be higher than water pressure) (Recommended chip air pressure)	(psi)	22 – 43.5 (29)***	
Exhaust air pressure	(psi)	< 7	
Operating pressure	(psi)	36 – 58	–
Recommended operating pressure	(psi)	43.5 + 3	36 – 41
Air consumption	(CFM)	> 1.59	> 1.59
Chip air consumption at 29 psi	(CFM)	> 0.053	> 0.053

rpm = min<sup>-1</sup> (Revolutions per minute)

\* see page 45

\* Multiflex® is a registered trademark of Kaltenbach & Voigt GmbH, Germany.



\*\* When using longer rotary instruments the user must ensure by correct selection of the operating conditions, that there is no danger to the user, patient or third parties.

\*\*\*Chip air pressure / water pressure must be set at the same time.

Chip air pressure must be higher than water pressure.

Power and speed data of turbine handpieces are largely dependent on the quality of the turbine hoses used and may therefore differ from the specified values.

## Temperature information



Temperature of the medical device on the operator side:

maximum 131°F (55°C)

Temperature of the medical device on the patient side:

maximum 122°F (50°C)

Temperature of the working part (dental bur):

maximum 105.8°F (41°C)

## Ambient conditions

Temperature during storage and transport:

-40°F to +158°F (-40°C to +70°C)

Humidity during storage and transport:

8% to 80% (relative), non-condensing

Temperature during operation:

+50°F to +95°F (+10°C to +35°C)

Humidity during operation:

5% to 80% (relative), non-condensing

## 11. Disposal

---



Ensure that the parts are not contaminated on disposal.

### Instrument disposal



Follow your local and national laws, directives, standards and guidelines for disposal.

- > Medical device
- > Packaging

# Warranty

Patterson warrants all products in this document against defects in material or workmanship for one year from time of delivery. Patterson's sole obligation under the warranty is to provide parts for the repair, or at its option, to provide the replacement product (excluding labor). The buyer shall have no other remedy. All special, incidental and coincidental damages are excluded.

Written notice of breach of warranty must be given to Patterson within the warranty period. The warranty does not cover damage resulting from improper installation or maintenance, accident or misuse. The warranty does not cover damage resulting from the use of cleaning, disinfecting or sterilization chemicals and processes. Failure to follow instructions provided in the Patterson owner's guide (operation and maintenance instructions) may void the warranty.

No other warranties as to merchantability or otherwise are made.





**Manufactured for:**

**Patterson Dental Supply, Inc.  
1031 Mendota Heights Road  
St. Paul, MN 55120  
pattersondental.com  
800-873-7683**

**Form-Nr. 50958 AEN  
Rev. 000 / 06.06.2019  
Subject to alterations**